

RADEON™ MAC® EDITION USER'S GUIDE



RADEON™ MAC® EDITION User's Guide

Version 2.0 - June 2001

P/N: 107-40214-20

Copyright © 2000, ATI Technologies Inc.

ATI and RADEON™ are trademarks and/or registered trademarks of ATI Technologies Inc. All other company and/or product names are trademarks and/or registered trademarks of their respective manufacturers. Pricing, availability, features, performance and specifications are subject to change without notice. Product may not be exactly as shown in the diagrams.

All rights reserved, including those to reproduce this manual or parts thereof, in any form without the express written permission of ATI Technologies Inc.

Disclaimer

While every precaution has been taken in the preparation of this document, ATI Technologies Inc. assumes no liability to any party for errors or omissions contained in the Software or related documentation, any interruption of service, loss or interruption of business or anticipatory profits or for incidental or consequential damages in connection with the furnishing, performance, or use of the Software and related documentation.

ATI Technologies Inc. reserves the right to make changes without further notice to a product or system described herein to improve reliability, function or design.

Multimedia Support

While RADEON™ MAC® EDITION provides full support for 2D graphics, 3D graphics, and QuickTime -- multimedia functionality may be limited under Mac® OS X.

Please refer to our website at www.ati.com for the latest information on how ATI continues to work with Apple to provide complete multimedia support.



Table of Contents

1. Getting Started	1
Introduction	1
What You'll Need.....	2
Related Documentation.....	2
2. Installing Your Hardware	3
Installing your RADEON™ MAC® EDITION	4
About Monitor Sensing.....	8
3. Installing Your Software	11
About ATI Software	11
Installing Software	12
4. Multimedia Features	13
Viewing 3D Graphics	14
ATI Displays Control Panel.....	15
Using QuickTime Playback	22
Using Mac2TV™ Video Out.....	23
Using Digital Flat Panel (DVI-I) Support.....	30
A. Troubleshooting Tips	33
Before Contacting Customer Support	33
Solutions to Common Problems	33
B. Specifications	37
Video Mode Table	37
Specifications.....	41
C. Compliance Information.....	43
D. Glossary.....	47

Getting Started



Introduction

The RADEON™ MAC® EDITION represents the next generation in 3D and video acceleration for your Power Macintosh computer. The RADEON™ graphics chip is equipped with all the 3D hardware drawing capabilities in demand by 3D high end users. Your new graphics accelerator provides:

- OpenGL® and QuickDraw 3D accelerator providing superior 3D rendering performance and advanced imaging and filtering techniques
- QuickDraw accelerator supporting 2D resolutions up to 1920x1440 in 32-bit color
- QuickTime playback accelerator for full screen, full motion, TV quality video
- DVI-I support for digital flat panels
- TV-Out support via S-Video connector

The easy-to-access, easy-to-use ATI Config Menu, on the menu bar, provides access to ATI Guide, giving you instant access to help, and the ATI Displays control panel, providing quick access to all of RADEON™ MAC® EDITION easy-to-use features such as TV/Video Out. Specific RADEON™ MAC® EDITION help can be accessed from the Apple Help in the menu bar.



A glossary of the bold terms used throughout this manual is available in the [“Glossary” on page 47](#) of this user guide and also in the ATI Guide.

What You'll Need

The RADEON™ MAC® EDITION runs with the following minimum system requirements:

- Power Macintosh or Mac OS compatible computer, with PowerPC processor, with an AGP or PCI expansion slot
- Mac OS 9.0 or later software
- Apple monitor, VGA-style monitor (*see note below*), DVI-I style digital flat panel, or TV
- QuickTime 4.0 or later (*see note below*)
- Apple OpenGL 1.15 or later
- Minimum 32MB of system memory (OpenGL 1.15 requires 32MB of system memory)



Apple analogue monitors without a VGA connector must use the included adapter to connect to the RADEON™ MAC® EDITION'S graphic accelerator. Apple digital monitors using the Apple Digital Connector (ADC) is not supported and no adapter is available.

Supports both QuickTime 4.0 and QuickTime 4.0 Pro.

Related Documentation

The README file summarizes the latest product revisions. Click the README icon on the installation disk to open this file.

The RADEON™ MAC® EDITION comes with ATI Guide, which provides on-line help for making the best use of your card's features. There are two methods of accessing the ATI Guide. From the Mac OS menu bar under the ATI icon, choose ATI Guide. From the ATI Displays control panel, you can access the ATI Guide by clicking on the Apple Guide  icon. RADEON Help can be found in the Apple Help menu.



Installing Your Hardware

The RADEON™ MAC® EDITION fits into connectors called expansion slots, inside your computer.

Your Mac OS computer has one or more expansion slots designed to accept Peripheral Component Interconnect (PCI) cards and Accelerated Graphics Port (AGP) cards.



WARNING

- The manufacturer assumes no liability for any damage, caused directly or indirectly, by improper installation of components by unauthorized service personnel. **If you do not feel comfortable performing the installation, consult a qualified technician.**
- Make sure power is off during installation; otherwise, damage to system components, the graphics accelerator card, and injury to yourself may result.



The following procedure details the installation of a card in a typical Mac OS PCI-based tower. If your computer does not match this configuration, please refer to the expansion card installation instructions that came with your computer.



IMPORTANT

- If your computer stops responding (hangs) after installing the RADEON™ MAC® EDITION video card, you may have an incompatible graphics accelerator extension. This can occur when Mac OS software or other ATI graphic accelerator cards are installed.
- Restart your computer and hold down the SHIFT key during startup. This disables all extensions from loading. After disabling extensions, you can update the graphics accelerator extension by installing the software included with your card. For more information about installing the software, see [“Installing Software” on page 12](#)

Installing your RADEON™ MAC® EDITION

- 1 Turn off your computer, and disconnect the monitor cable.
- 2 Open your computer. If necessary, consult your computer system manual for instructions.



- 3 Choose the AGP or PCI expansion slot you wish to use.
- 4 Touch the metal part of the power supply case.

Touching the grounded portion of the power supply case will discharge your body's static electricity.

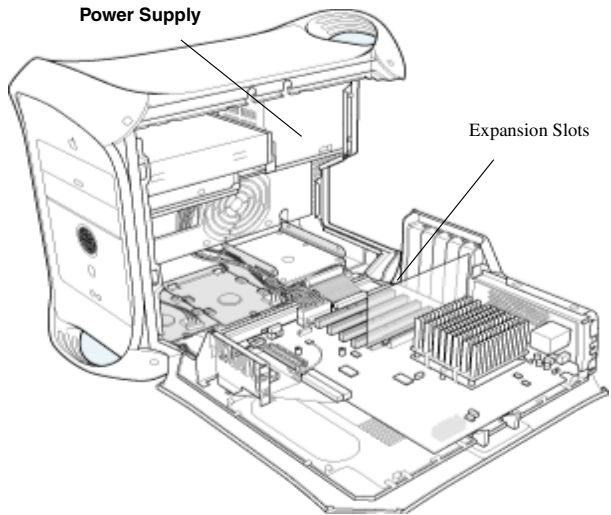

- 5 Align the connector on the card with the selected expansion slot, and press firmly until fully seated.

AGP Connector

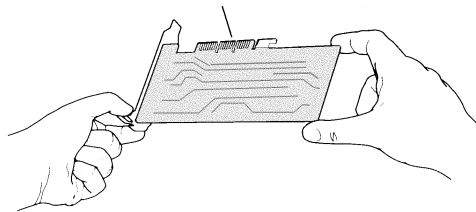

PCI Connector

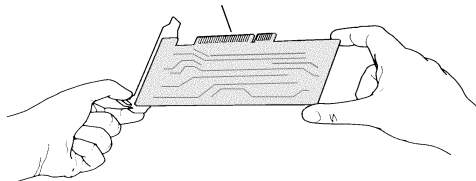

Do not force the card. It should fit snugly into the expansion slot.

If you are not sure whether your card is PCI or AGP, compare its bottom edge with the following illustration:

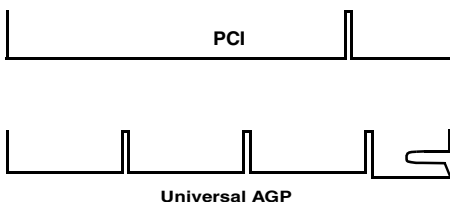

If you plan to use more than one monitor, you must install a card for each monitor. Repeat steps 6 and 7 for each card.

- 6** Close the computer case.
- 7** Connect the monitor cable to the card.

If you have a VGA monitor, connect it to the VGA monitor port. If you have a TV, connect it to the TV Out port. If you have a digital flat panel, connect it to the DVI-I port.

To connect an Apple monitor to the RADEON™ MAC® EDITION card, you will need an Apple adapter. Simply connect your Apple monitor connector to the Apple adapter, and then plug the Apple adapter into the VGA monitor port.

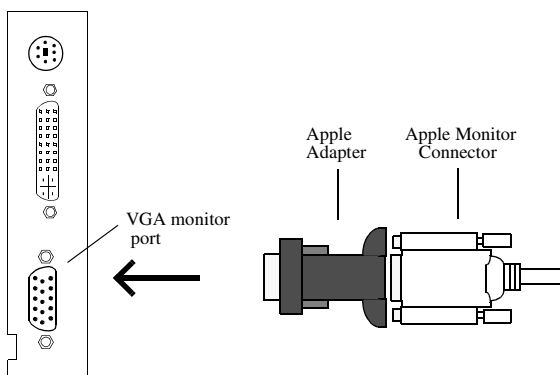

Installation of your RADEON™ MAC® EDITION card is now complete, and you are ready to install the software. See [“Installing Your Software” on page 11.](#)



Powered Apple monitors using the ADC (Apple Display Connector) is not supported.

About Monitor Sensing

Apple's Monitor Sensing specification allows video display cards to identify the attached monitor. The RADEON™ MAC® EDITION auto-configures itself according to the monitor sense code detected and enables all resolutions supported by the monitor. Since the RADEON™ MAC® EDITION relies on this sense code to correctly auto-configure during startup, the monitor must supply the appropriate sense code.

On VGA monitors, the RADEON™ MAC® EDITION card uses the Display Data Channel (DDC) protocol, which is similar to Apple's Monitor Sensing specification, to determine the possible resolutions and frequencies. All possible resolutions are shown in the Monitors & Sound control panel and the Apple control strip.

When using older VGA monitors without DDC, you must choose the resolutions supported by your VGA monitor in the VGA Monitors section of the ATI Displays control panel. See [“VGA Monitors” on page 18](#) for additional information.

If you are using a display adapter and the adapter supplies the sense code information for only one resolution, then that resolution will be the only one available, even if the monitor supports multiple resolutions. A resolution of 640x480 is usually the default resolution. Therefore, when using an adapter to supply the sense code, it must be designed to supply the proper code for the monitor you are using it with; otherwise, the RADEON™ MAC® EDITION cannot correctly auto-configure itself for the attached monitor.

Although the RADEON™ MAC® EDITION card does not output Sync-on-Green (SOG) signals directly, adapters are available that can overlay the Composite Synchronization Signal and send it through the Green video signal line so that you can use an SOG monitor. Monitors requiring an SOG signal usually have only three BNC connectors (RGB).

For more information about obtaining a sense code or synchronization signal adapter, contact ATI Customer Support or ask your dealer. For information about how to contact ATI Customer Support, select the Support button on the ATI Displays control panel.

3

Installing Your Software

About ATI Software

The RADEON™ MAC® EDITION requires several additional components be added to your System folder. The ATI RADEON™ MAC® EDITION Installer application does this for you, installing the following components:



ATI Displays Control Panel

The ATI Displays control panel lets you configure your card and access software and hardware features. These features are described in the section [“ATI Displays Control Panel” on page 15.](#)



ATI Multimedia Components

ATI’s Multimedia Components are placed in the Extensions folder, located within System Folder. They enable all of the advanced features of your card, including 3D and 2D acceleration.



ATI Guide File

The ATI Guide file is the on-line help for the ATI Displays control panel. It is placed in the Extensions folder within the System folder. ATI Help, specifically for RADEON™ based products, is placed in the Help folder found in the System Folder. For more information about using the on-line HELP system, see [“ATI HELP” on page 21.](#)

Installing Software

- 1 Insert the ATI Installation CD.
- 2 Double-click on the RADEON™ MAC® EDITION Installer icon.

The ATI splash and legal notice screens appear.

- 3 Follow the instructions that appear on the screen.

Upon completion of the installation process, a file containing a list of installed files and their location on your hard disk is created allowing you to locate any file installed during the installation process.



The installer application checks your system to determine if you have the latest versions of the required software. If you do not have the appropriate Apple software, a dialog appears explaining what software needs to be installed. (The RADEON™ MAC® EDITION accelerator card requires Apple OpenGL 1.1.5 or higher which can be downloaded from www.apple.com.)

- 4 When you see a message that the installation was successful, click Restart.

Your computer restarts.

or

To perform further installations, click OK.

You need to manually restart your computer to complete the installation of the RADEON™ MAC® EDITION software.



Multimedia Features

Your RADEON™ MAC® EDITION turns your Mac computer into a 3D and 2D graphics powerhouse. You can use your new graphics accelerator card to do the following:

- Experience the latest arcade style and virtual reality games the way they were meant to be played with state-of-the-art 3D graphics using OpenGL acceleration.
- Enjoy true-color 32-bit 2D or 3D graphics up to 1920x1440.
- Watch full screen, full motion, TV-quality video using QuickTime playback acceleration.
- Output your Mac's display to a digital flat panel
- Output your Mac's display to your TV

The following information describes these new 3D and multimedia features in more detail and suggests ways you can optimize your machine to get the most out of your new card.

Viewing 3D Graphics

RADEON™ MAC® EDITION's 3D Acceleration features supports the following advanced 3D graphics capabilities:

- OpenGL Support
- QuickDraw 3D Rave Support
- Integrated Transformation, Clipping and Lighting
- Twin Cache Architecture
- Single Pass Multi-texturing
- Triangle Setup Engine
- Bilinear/Trilinear Filtering
- Line & Edge Anti-aliasing
- Full Screen Anti-aliasing
- Specular Highlights
- Perspectively Correct Texture Mapping
- Mip-Mapping
- Z-buffering and Double-buffering
- Spherical, Dual-Paraboloid and Cubic environment mapping

These features make it possible to quickly render 3D graphics, produce atmospheric effects, calculate light and color shading, and determine which objects are in the foreground and which are in the background.

RADEON™ MAC® EDITION only displays 3D graphics in thousands and millions of colors. When you use 256 colors, there are too few colors to display complex 3D textures, so 3D acceleration is not supported.

You can use the 3D Memory Monitor to see how memory on your RADEON™ MAC® EDITION is allocated when displaying 3D graphics. This allows you to optimize 3D performance.

ATI Displays Control Panel

The ATI Displays control panel provides access to the advanced 3D features that RADEON™ MAC® EDITION has to offer. To open the ATI Displays control panel, choose Control Panels from the Apple menu, then choose ATI Displays, or choose ATI Displays from the ATI Config Menu from the Mac OS menu bar.

For detailed instructions on how to set up and use these features, please refer to the ATI Guide/ATI Help, which can be accessed through the ATI Displays control panel.



Status Area

Look in the Status Area to determine your current monitor, screen resolution, and color depth. To change these settings, use the Monitors feature to open the Monitors control panel. You can also change the monitor depth and resolutions at any time using the Apple control strip, if installed.





Identify Displays

If you have more than one display connected to your computer, you can identify and configure each display. The ATI Displays control panel identifies all the displays connected to your computer, but only configures displays that are connected to ATI cards.



If you are using multiple monitors and using one display with the built-in video, or a non-ATI video card, a generic video card icon is displayed in the ATI Displays control panel. However, you cannot make any changes to the generic video card using ATI Displays.



Display Details

The Details window gives you information about specific software components needed to enable each of RADEON™ MAC® EDITION's features. Check the Details window to determine the files and version numbers of the software components installed in your system folder during the installation process. Using the pull-down menu, the Details window also lists the Mac OS multimedia software required for RADEON™ MAC® EDITION, such as QuickDraw 3D and OpenGL

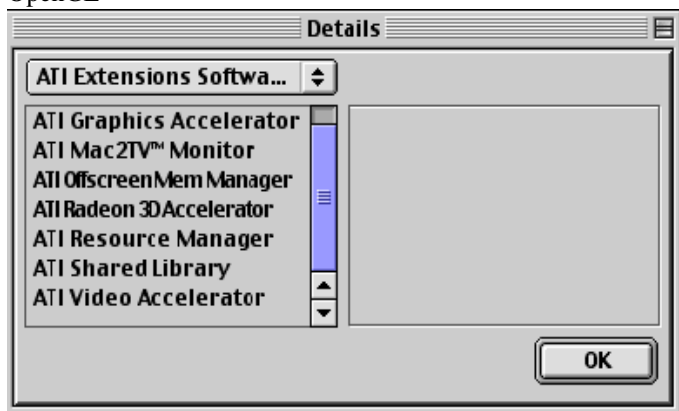



Monitors

The Monitors feature provides access to the standard Mac OS Monitors control panel. You can use the Monitors control panel to select color depths and resolutions, and set up multiple monitors. For more information on the Monitors control panel refer to the Mac OS Guide that comes with your computer.

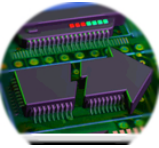

Keyboard Shortcuts

This feature allows you to use a pop-up menu to change your desktop settings without exiting your current application. You can configure, enable or disable shortcut features when you click the Shortcut icon in the control panel.

The ATI Popup Menu only displays the valid and safe modes available for the attached monitor(s). Additional modes may be accessed through the Monitors control panel or the Control Strip.



Different ATI cards offer distinct keyboard shortcut options, so not all shortcuts appear on every ATI card.

Popup Menu and Hot Keys remain inactive when dialogs appear on the screen. For example, while using the Monitors control panel, the Popup Menu and Hot Keys are disabled.

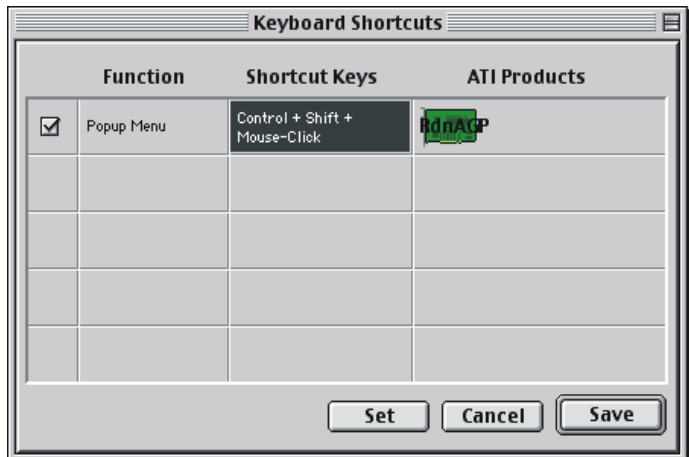

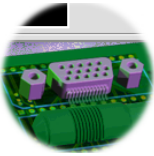

VGA Monitors

If you have a non-DDC compliant VGA monitor connected to your RADEON™ MAC® EDITION, the VGA icon may be active. Some VGA monitors use a Display Data Channel (DDC). You do not have to do anything extra to select the supported resolutions. Your RADEON™ MAC® EDITION uses the DDC information to automatically provide the supported resolutions in the Monitors control panel and the Control Strip. If your VGA monitor doesn't use DDC, the VGA Monitors icon is active, and you must use it to select your monitor from a list of standard monitors.



If the VGA icon is dimmed, your computer has detected an Apple-type monitor, or a DDC compliant VGA monitor connected to your RADEON™ MAC® EDITION. You do not have to make a selection.

To Select a VGA Monitor

- 1 Select VGA Monitors from the ATI Displays control panel.
- 2 Select your VGA model from the list of monitors in the left panel of the VGA Monitors dialog box.

A list of resolutions supported by your VGA monitor appears in the right panel of the VGA Monitors dialog box.



You cannot select the monitor resolution using the VGA Monitors dialog box. You must use the standard Mac OS Monitors control panel.

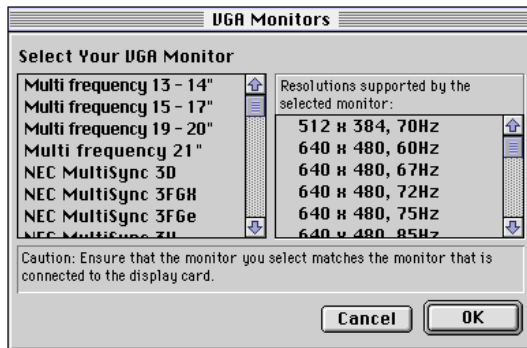

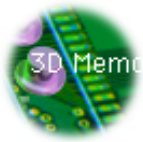

3D Memory Monitor

The 3D Memory Monitor shows how available memory in the accelerator card is allocated when displaying 3D graphics.

Using the 3D Memory Monitor

When you open 3D graphics on your Mac OS computer, run the 3D Memory Monitor to see how your RADEON™ MAC® EDITION has allocated 3D memory.

To open the 3D Memory Monitor

- 1 Choose Control Panels from the Apple Menu, or choose ATI Displays from the ATI Config Menu and skip to step 3.
- 2 Select ATI Displays.
- 3 Click on the 3D Memory icon.

When you open a 3D application window, you can see how the additional memory required for 3D graphics is allocated.

The 3D Memory Monitor shows you how the memory on your RADEON™ MAC® EDITION has been allocated between display, textures, and buffers.

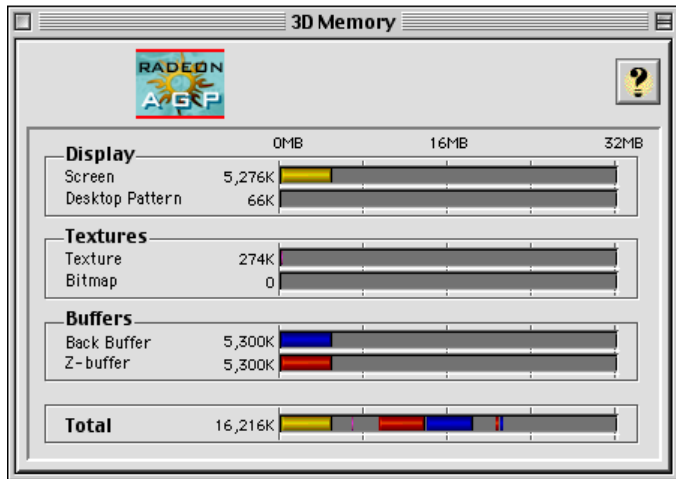

Display

The Screen bar indicates the amount of graphics memory allocated to the display's resolution and color depth. The

Desktop Pattern bar indicates the amount of memory used by your desktop pattern.

To reduce the memory allocated to Display memory:

- change the color depth from millions to thousands
- decrease your screen resolution

Textures

The **Texture** bar indicates the number and size of texture maps loaded by 3D applications to add realism to 3D models and environments. The **Bitmap** bar indicates the memory allocated to non-3D elements like 2D graphics. To reduce the memory allocated to Texture memory, reduce the amount of textures in your 3D graphic.

Buffers

The **Back Buffer** bar and the **z-buffer** bar are directly related to the size of the 3D window.

To reduce the memory allocated to Buffer memory:

- reduce the size of the display window containing 3D graphics
- reduce the number of the display windows containing 3D graphics



ATI HELP

The ATI HELP is an additional source of information when you are using the ATI Displays control panel. It behaves similarly to the Mac OS Guide that comes with your computer.

Access the ATI HELP by clicking on the Apple HELP  icon on the ATI Displays control panel, or the ATI Config Menu. From the ATI DISPLAYS GUIDE select RADEON then OPEN RADEON HELP. Finally, select ATI HELP from the HELP CENTER.

Select a topic from the main ATI HELP window to get detailed instructions for a specific task. To return to the main ATI HELP window, click the HOME icon in the upper-left corner of the HELP window.

Customer Support



You can obtain Customer Support information by clicking the ATI icon in the ATI Displays control panel. You can also generate a problem report.



Please refer to the ATI DISPLAYS GUIDE for additional instructions on generating a problem report.

Before calling about a suspected problem, please complete the problem report, and have the report file either on-screen or printed out for reference during your call. Important information about your computer is automatically included when you generate the report.

Using QuickTime Playback

The RADEON™ MAC® EDITION's QuickTime playback acceleration allows you to stretch even the smallest movies to full screen size without compromising frame rate or image quality. RADEON™ MAC® EDITION's hardware scaler maintains the original quality of your QuickTime movie when scaling to a larger size – even full screen.

The RADEON™ MAC® EDITION's QuickTime playback acceleration displays in millions of colors, even if the current color depth setting is 256 colors. When the monitor is set to display in grayscale, QuickTime movies are accelerated in grayscale, they are not converted to color. When scaling video, RADEON™ MAC® EDITION uses special hardware techniques (alpha blending and chroma interpolation) to enhance the video quality instead of just repeating pixels.



To use RADEON™ MAC® EDITION's playback acceleration, you must have QuickTime version 4.0 or greater installed on your computer.

Optimizing Video Playback

When you scale a movie, your computer switches from QuickTime's software scaler to RADEON™ MAC® EDITION's hardware scaler to produce better results. However, QuickTime will not switch to hardware scaling in the following situations:

- playing video in double size
Try manually scaling the video slightly off exactly double the size.
- pausing the video
- using single frame advance
- watching the video in reverse
- playing a video that has not been saved in Cinepak, Indeo, or MPEG-1 compressed format

QuickTime clips must be in Cinepak (the most common QuickTime movie format), Indeo, or MPEG-1 format to be scaled by RADEON™ MAC® EDITION. To determine if a video will be accelerated using RADEON™ MAC® EDITION's hardware scaler, check the video format.

To check the format of a video

- 1 Open the movie using QuickTime Player.
- 2 Choose Get Info, from the Movie menu.
- 3 From the 1st pull down menu, select Video Track.
- 4 From the 2nd pull down menu, select Format.
- 5 Read the format type. Remember, only Cinepak, Indeo, and MPEG-1 formats use RADEON™ MAC® EDITION's QuickTime acceleration and hardware scaler.



Some multimedia titles on CD-ROM incorporate QuickTime clips that do not allow movies to be stretched during playback. These QuickTime clips cannot be accelerated while viewing the multimedia title.

Using Mac2TV™ Video Out

The RADEON™ MAC® EDITION's Mac2TV™ Video Out feature allows you to output your computer's display to your TV or VCR. Anything you can display on your monitor can be output to TV.

- View computer output directly on your television in either NTSC or PAL formats with advanced flicker reduction and artifact suppression
- Connect using Composite or S-Video output capabilities
- RADEON™ MAC® EDITION provides a big-screen experience for playing games, giving presentations, and browsing the Internet.

Using RADEON™ MAC® EDITION's TV/Video Out Connector

To output your computer's display to a TV

- 1 Turn off your computer and TV.
- 2 Ensure your RADEON™ MAC® EDITION is installed correctly.
- 3 Looking at the back of your Mac, locate your RADEON™ MAC® EDITION.
- 4 Determine if your TV has an S-Video or Composite video input connection.

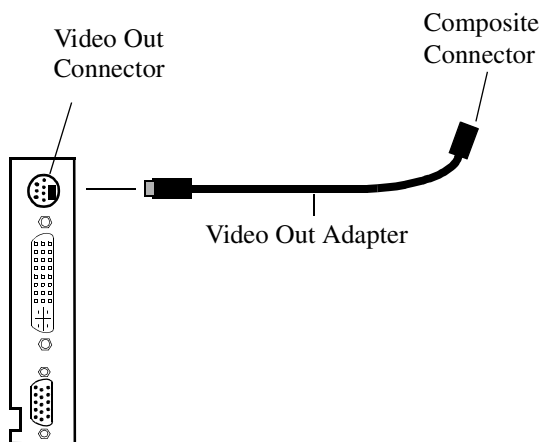

- 5 If you are using S-Video connection to the TV attach one end of an S-Video cable to the S-Video out connection of the RADEON™ MAC® EDITION and the other end to the S-Video In connector of your TV. If you are using Composite connect the supplied Video Out Adapter cable to the S-Video connector of the RADEON™ MAC® EDITION. Then attach one end of your Composite cable to the Composite connector and the other end to the Composite In of your TV (See diagram above).
- 6 Turn on your Mac and your TV.



Now that you have connected your RADEON™ MAC® EDITION to a TV, you need to enable Mac2TV. For more information, see “Enabling Mac2TV™” on page 27.

To connect your computer’s display to a VCR to record to video tape

- 1 Turn off your computer and VCR.
- 2 Ensure your RADEON™ MAC® EDITION is installed correctly.
- 3 Looking at the back of your Mac, locate your RADEON™ MAC® EDITION
- 4 Determine if your VCR has an S-Video or Composite video input connection.

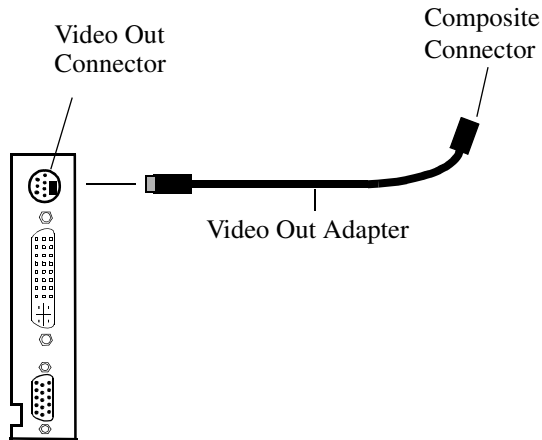

- 5 If you are using S-Video attach one end of an S-Video cable to the S-Video Out connector of the RADEON™ MAC® EDITION and the other to the S-Video In connector of your VCR. If you are using Composite connect the supplied Video Out Adapter cable to the S-Video connector of the RADEON™ MAC® EDITION. Then attach one end of your Composite cable to the Composite connector and the other end to the Composite In of your VCR (See diagram above).
- 6 Turn on your Mac, VCR, and TV.

If you are connecting your RADEON™ MAC® EDITION to a VCR, make sure that your VCR is connected to a television that you can use as your computer's display. For information about connecting a television to your VCR, see the documentation supplied with your VCR.

Now that you have connected your RADEON™ MAC® EDITION to a VCR, you need to enable Mac2TV™.

Enabling Mac2TV™



WARNING

- When you initially turn on Mac2TV Video Out, your monitor display will be dimmed. Monitors which do not support the 60 Hz vertical refresh rate required by video equipment may be damaged when Mac2TV is enabled. Dimming your monitor is a safety feature, protecting your monitor from any potential damage.
- Many newer Apple and VGA multi-frequency monitors are capable of supporting the 60 Hz vertical refresh rate at several resolutions. If you are certain that your monitor supports this refresh rate (check your monitor User's Guide), restore the monitor display by choosing one of the simulscan modes shown in the Monitors control panel and the control strip. Older versions of ATI graphics accelerator cards may be able to restore the monitor display by pressing \mathcal{A} -Option-m-o together.
- Most DVI-I panels do not support 60Hz vertical refresh rate and will therefore not support simulscan modes.

- 1 Open the ATI Displays control panel.
- 2 Click on the Mac2TV icon.
- 3 In the Video Output box, click Video Output On.

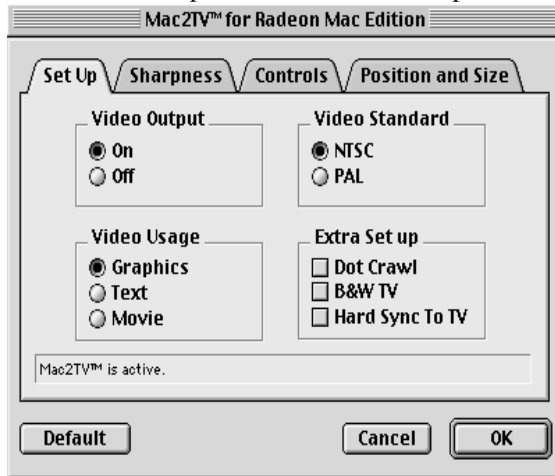

A message appears, warning you your monitor will be dimmed.



- 4** Click OK.

A message appears on your TV stating that your display has been successfully switched to TV.



- 5** Click OK.

If you do not click OK to the message on the TV, your display will return to your monitor after a few seconds.

Changing Display Configurations

Using a TV as your only display

If you are using television display only, disconnect your monitor from your RADEON™ MAC® EDITION. The RADEON™ MAC® EDITION detects that you have a TV attached and automatically starts with Mac2TV display enabled.

Optimizing Mac2TV

You can optimize your TV display using the video out preferences. Viewing images on your TV can be improved by changing the contrast, brightness, or size of your display.

To set the video out preferences, click the Mac2TV icon on the ATI Displays Control Panel.

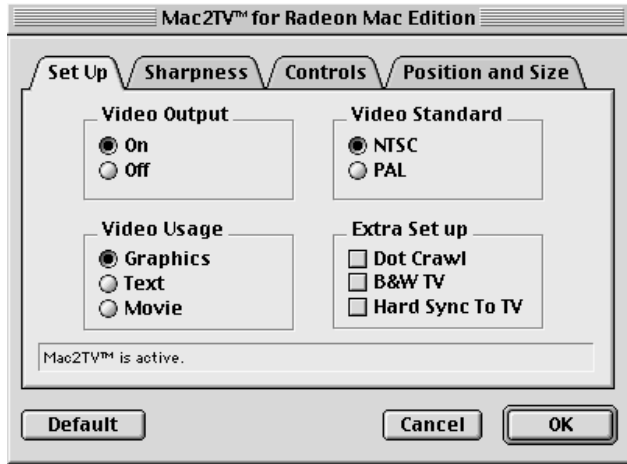

Hue, saturation, and brightness are the three qualities which constitute what we normally refer to as “color”.

- **Hue**, often used as a synonym for “color”, is the quality that distinguishes among red, green, yellow, and so on.
- **Saturation** is the amount of color present that distinguishes pale or washed-out colors from vivid ones.
- **Brightness** is related to the amount of light emitted by your display or reflected from an object. This quality enables you to describe an object as “bright” or “dim”.

Hue is generally not adjusted. Depending on the TV, however, it may be necessary or desirable to adjust the hue to approximate the monitor’s display.

Anti-Flicker reduces the amount of display flicker. Display flicker is both a distraction and tiring to your eyes, and is most pronounced when text is being displayed.

Dot Crawl is an undesirable characteristic of many Composite televisions that is seen as thin, jagged edges moving around objects on the screen. The “Frozen” setting freezes, or eliminates, the dot crawl, and is especially useful for viewing pictures or stills. S-video equipment does not exhibit this effect.

Contrast is a ratio of how far the whitest whites are from the blackest blacks. If the contrast is too high, the image may look stark, like pure white squares on a jet-black background. If the contrast is too low, the image may look gray or washed out.

Reducing Edge Distortion

When using a television for your display, you may see some edge distortion on the left and right side of your television screen. This effect depends on your television and the application you are running.

To reduce edge distortion, you can:

- increase the horizontal size by clicking the right Size arrow, or
- reduce the brightness by adjusting the brightness slider.

Viewing Text on Television

Due to the different technology used in the manufacturing of televisions and monitors, standard text may look too small on your television. You can compensate for this by using larger fonts.

To change your font size

- 1 Click the Apple menu.
- 2 Select Control Panels.
- 3 Select Views.
- 4 Choose a larger font size.

Using Digital Flat Panel (DVI-I) Support

RADEON™ MAC® EDITION's DVI-I support feature allows you to output your computer's display to your DVI-I digital flat panel, providing you with:

- Crisper, clearer images.
- A true flat screen.
- Virtually no eye strain from prolonged viewing.



Using RADEON™ MAC® EDITION DVI-I Connector

Your RADEON™ MAC® EDITION includes support for DVI-I. You can use this feature to connect your RADEON™ MAC® EDITION to a digital flat panel display.

To output your computer's display to a DVI-I digital flat panel:

- 1 Turn off your computer and DVI-I flat panel.
- 2 Ensure your RADEON™ MAC® EDITION is installed correctly.
- 3 Looking at the back of your Mac, locate your RADEON™ MAC® EDITION.
- 4 Connect the DVI-I cable to the DVI-I connector on your RADEON™ MAC® EDITION. (See diagram below.)

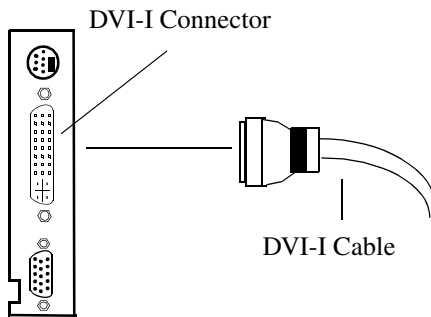

- 5 Locate the DVI-I *connector on your DVI-I flat panel.*
- 6 **Attach one** end of your DVI-I cable to the DVI-I connector on your RADEON™ MAC® EDITION and the other end to the DVI-I connector on your DVI-I flat panel.
- 7 Turn on your Mac and your DVI-I flat panel.

Your DVI digital flat panel is automatically enabled.

The RADEON™ MAC® EDITION can only support one VGA or DVI-I digital flat panel at a time.



Troubleshooting Tips

Before Contacting Customer Support

If you have a general question, or encounter problems with your card, please review this information completely before contacting Customer Support.

You can create a problem report from the ATI Displays control panel. Please refer to the ATI Guide for instructions on generating this problem report, and for general troubleshooting tips not covered in this section.

Before calling about a suspected problem, please complete the problem report, and have the report file either on-screen or printed out for reference during your call. Important information about your system is automatically included when you generate the report.

Solutions to Common Problems

Why can't I get a resolution higher than 640x480?



If the monitor is connected to the VGA monitor port on your RADEON™ MAC® EDITION...

- go to the ATI Displays control panel, click “VGA Monitors”, and select a monitor type that matches the specifications of your monitor. This allows more resolutions to be available for selection in the standard Mac OS Monitors control panel.

I have a monitor with three BNC connectors. Why won't it work with my RADEON™ MAC® EDITION?

- Monitors that only have three BNC connectors require a synchronization (“sync”) signal to be sent down the green line. This is called Sync-on-Green (SOG). ATI accelerator cards do not output a SOG signal. Adapters are available for your Mac OS computer to convert the separate sync signal from the ATI card to a SOG signal for the monitor. Check with your local Apple Authorized Dealer for availability of SOG adapters.

I have a monitor with five BNC connectors. Why won't it work with my RADEON™ MAC® EDITION?

- For a cable with five BNC connectors, ensure that they are all connected to the monitor. If only three of the cables are connected (i.e., R, G, and B), the monitor is expecting a Sync-on-Green (SOG) signal.
- Some monitors may have a switch to set the monitor to either SOG or separate sync. If the switch is set to SOG, the monitor will show a scrambled display. Setting the switch to separate/composite sync may resolve the problem.
- A number of BNC cables, even though they are designed for Mac OS computers, do not supply the sense code needed by the graphics card. Using an adapter that sets the appropriate sense code should solve the problem.

After selecting a VGA monitor type in the VGA Monitors dialog, I couldn't change the resolution in the Resolutions Supported scroll list.

- This scroll list in the ATI Displays control panel only shows the available resolutions for the monitor type selected, and will not allow you to select and change resolutions. Changing resolutions can only be done through the standard Monitors control panel, Control Strip module, or by using the Popup Menu supplied with the RADEON™ MAC® EDITION.

Does the RADEON™ MAC® EDITION work in all Power Macintosh computers?

- No, the RADEON™ MAC® EDITION only works with PCI and AGP based Power Macintosh computers. The minimum system requirements are listed in [“What You'll Need” on page 2.](#)

After installing RADEON™ MAC® EDITION, I noticed some sound distortion. Why?

- Installing the ATI Sound Catalyst extension corrects sound corruption in certain Macintosh computers. Additional information on the Sound Catalyst extension is available in the Read Me document in the Sound Catalyst folder.
- Disabling Virtual Memory in the Memory control panel may resolve this problem. Certain Mac OS computers may experience sound corruption while using QuickDraw 3D accelerated applications even with Virtual Memory turned off.
- If you still have sound related problems, check with the manufacturer of your Mac OS computer for any sound related software updates they may have.



Specifications

Video Mode Table

The video mode table below lists the color depth capabilities for the supported resolutions on your RADEON™ MAC® EDITION.

Please consult your monitor's specifications to determine which resolutions are available with your display.

Mac OS 2D Resolutions

Display Resolution	Vertical Refresh Hz	Horizontal Refresh kHz	Fixed Mac OS Monitor Size
512 x 384	60	24.48	12-in.
640 x 480	67	35.00	13-in./14-in.
832 x 624	75	49.72	16-in./17-in.
1024 x 768	75	60.24	19-in./20-in.
1152 x 870	75	68.68	21-in.

Supported VESA/VGA 2D Modes

Display Resolution	Vertical Refresh Hz	Horizontal Refresh kHz
512 x 384	60	24.48
640 x 480	60	31.48
	67	35
	72	37.50
	75	37.50
	85	43.27
	90	45.54
	100	50.89
	120	61.79
640 x 870	75	68.85
800 x 600	56	35.16
	60	37.88
	72	48.08
	75	46.88
	90	56.88
	100	63.60
	120	77.15
832 x 624	75	49.72
1024 x 768	60	48.36
	70	56.48
	75	60.02
	85	68.68
	90	72.81
	100	80.40
	120	96.76
1152 x 870	75	68.68
1280 x 960	75	75.00
1280 x 1024	60	63.98
	75	79.98
	85	91.38
1600 x 1024	76	81.32

Display Resolution	Vertical Refresh Hz	Horizontal Refresh kHz
1600 x 1200	60	75.00
	65	81.25
	70	87.50
	75	93.75
	85	106.25
1792 x 1344	60	83.38
	75	106
1856 x 1392	60	86.33
	75	112.50
1920 x 1200	76	95.00
1920 x 1440	60	90.00
	75	112.50

3D Mode Table

The 3D mode table measures the number of full screen 3D windows that are possible to display at a given resolution. For example, a value of 2.75 means that there is enough memory left over in the current mode to run 2 full screen 3D windows and another at 3/4 the size of full screen. A value of 0.40 means that largest 3D window will be just less than 1/2 the size of full screen.

In the following table, 3D windows are considered to use a back buffer and z-buffer.



3D acceleration is not supported when your color depth is 256 colors. In this color depth, there are too few colors to display complex 3D textures.

Resolution	Colors	Full screen 3D windows possible	
		32 MB 16-bit z-buffer	32 MB 32-bit z-buffer
512 x 384	Thousands	20.50	13.75
	Millions	13.25	10.00
640 x 480	Thousands	13.00	8.50
	Millions	8.25	6.25
800 x 600	Thousands	8.00	5.25
	Millions	5.00	3.75

Resolution	Colors	Full screen 3D windows possible	
		32 MB 16-bit z-buffer	32 MB 32-bit z-buffer
832 x 624	Thousands	7.50	5.00
	Millions	4.50	3.50
1024 x 768	Thousands	4.75	3.00
	Millions	2.75	2.00
1152 x 870	Thousands	3.50	2.25
	Millions	2.00	1.50
1280 x 1024	Thousands	2.50	1.75
	Millions	1.25	1.00
1600 x 1200	Thousands	1.50	1.00
	Millions	0.75	0.50

Specifications

System Requirements

- Power Macintosh or Mac OS compatible computer with an AGP slot

Operating System

- Mac OS software (version 9.0 or higher)
- QuickTime (version 4.0 or higher)
- Apple OpenGL 1.1.5 or higher

Graphics Controller

- ATI RADEON — graphics and multimedia accelerator chip

Video Display Buffer

- 32MB memory
- 256-bit memory interface

Bus

- **AGP:** AGP 2x
- **PCI:** 32-bit PCI local bus compliant with PCI version 2.1 specification 33 or 66MHZ compatible.

Sync Signals

- Separate horizontal and vertical sync at TTL levels
- Composite sync at TTL levels

Video Memory Address

- Supports PCI Multimedia Standard
- Supports 64MB relocatable memory aperture

Display Connector

- DVI-I connector

VGA Connector - Standard VGA

Monitors with Apple connectors are supported using the Apple-to-VGA video adapter (included).

- S-Video Out (Composite Out adapter included)

Video Interrupt

- PCI interrupt request enabled; interrupt is auto- configured by system

Power

- +5V $\pm 5\%$, @ 1.3A typical

Environment

- Ambient Temperature: 50° to 122° F (10° to 50° C) operation. 32° to 162° F (0° to 70° C) storage
- Relative Humidity: 5% to 90% non-condensing operation, 0% to 95% storage

MTBF

- 120,000 hours

EMC Certification

- FCC Class B

Safety

- PCB made from UL-listed flame retardant material



Compliance Information

FCC Compliance Information

This device is in conformity with part 15 of the FCC Rules. Operation of this product is subject to the following two conditions: (1) this device may not cause harmful interference, and (2) this device must accept any interference received, including interference that may cause undesired operation.

This equipment has been tested and found to comply with the limits for a Class B digital device, pursuant to Part 15 of the FCC Rules. These limits are designed to provide reasonable protection against harmful interference in a residential installation.

This equipment generates, uses and can radiate radio frequency energy and, if not installed and used in accordance with manufacturer's instructions, may cause harmful interference to radio communications. However, there is no guarantee that interference will not occur in a particular installation.

If this equipment does cause harmful interference to radio or television reception, which can be determined by turning the equipment off and on, the user is encouraged to try to correct the interference by one or more of the following measures:

- Re-orient or relocate the receiving antenna.
- Increase the separation between the equipment and receiver.
- Connect the equipment to an outlet on a circuit different from that to which the receiver is connected.

Consult the dealer or an experienced technician for help.

- The use of shielded cables for connection of the monitor to the graphics card is required to ensure compliance with FCC regulations.
- Changes or modifications to this unit not expressly approved by the party responsible for compliance could void the user's authority to operate this equipment.

Industry Canada Compliance Statement

ICES-003 This Class B digital apparatus meets all requirements of the Canadian Interference-Causing Equipment Regulations.

Cet appareil numérique de la Classe B Respecte toutes les exigences du Règlement sur le matériel brouiller du Canada.

CE Compliance Information

EMC Directive 89/336/EEC and Amendment 92/31/EEC, Class B Digital Device

EN 50081-1, Generic Emissions Standard for Residential, Commercial and Light Industrial Products

(EN 55022/CISPR 22, Limits and Methods of Measurement of Radio Interference Characteristics Information Technology Equipment)

Warning: This is a Class B product. In a domestic environment this product may cause radio interference in which case the user may be required to take adequate measures.

EN 50082-1, Generic Immunity Standard for Residential, Commercial and Light Industrial Products

(EN 61000-4-2, EN 61000 -4-4, EN 61000-4-6)

Directive EMC 89/336/CEE et amendement 92/31/CEE, dispositif numérique de Classe B

EN 50081-1, Norme sur les émissions génériques pour les produits domestiques, commerciaux et industriels légers

(EN 55022/CISPR 22, Limites et méthodes de mesure des caractéristiques d'interférences radiophoniques, Matériel des technologies de l'information) *Mise en garde: ceci est un produit de Classe B. Il risque produire des interférences radiophoniques dans un environnement domestique auquel cas l'utilisateur peut se voir demandé de prendre des mesures adéquates.*

EN 50082-1, Norme sur l'immunité générique pour produits domestiques, commerciaux et industriels légers.

(CEI 801-2, CEI 801-3, CEI 801-4)

EMC Richtlinie 89/336/EEC und Änderung 92/31/EEC, Digitales Gerät der Klasse B

EN 50081-1, Allgemeiner Emissions-Standard für Haushalt- und kommerzielle Produkte sowie Erzeugnisse der Leichtindustrie

(EN 55022/CISPR 22, Beschränkungen und Verfahren der Messung von informationstechnischen Ausrüstungen mit Funkstörmerkmalen)

Warnung: Dies ist ein Erzeugnis der Klasse B. Dieses Erzeugnis kann Funkstörungen im Wohnbereich verursachen; in diesem Fall können entsprechende Maßnahmen seitens des Benutzers erforderlich sein.

EN 50082-1, Allgemeiner Unempfindlichkeits-Standard für Haushalt- und kommerzielle Produkte sowie Erzeugnisse der Leichtindustrie

(EN 61000-4-2, EN 61000 -4-4, EN 61000-4-6)



Glossary

- Alpha blending** When an image has an alpha value for each pixel, this tells how much to blend the colors from the image with the background colors. The lower the alpha values the more transparent the image looks.
- Anti-aliasing** Method used to remove the jaggedness of an image. When anti-aliasing is used, the edges of an image appear smooth and usually somewhat blurry.
- Back buffer** A type of **offscreen memory** used to provide smooth video and 2D graphics acceleration. This technique uses two frame buffers, often referred to as "double-buffering". While one buffer is being displayed, a second buffer of the same size, the "back" buffer, holds the frame being worked on.
- Once a new frame is ready in the back buffer it is copied to the front buffer - the display screen. In this way, you will only see complete, smooth frames, and not the operations performed on them.
- In order to increase performance, all memory used for back buffers are on your ATI graphic accelerator card.
- Bilinear Filtering** When texture mapping is performed an image can become very "blocky" or "pixelated" when the texture is viewed close up. Bilinear filtering samples four texture pixels, takes the weighted average of these pixels and applies the average of these "texels". This blended color is used to provide a smoother looking texture.
- Bitmap** A bitmap is a graphics or character representation composed of individual pixels, arranged horizontally in rows. A monochrome bitmap uses one bit per pixel (bpp). Color bitmaps may use up to 32-bpp, depending on the number of colors desired.
- Buffers** Your ATI accelerator card includes on-board memory which is used in a number of ways. Buffers are portions of this memory used as temporary storage on your card. One large buffer is always used to display the screen you see; this is the "display buffer". The rest of **offscreen** memory is used by applications as **back buffers**, **z-buffers**, and texture buffers.

Color Depth	Color depth is the number of color shades available on your display. The color depth of your monitor usually includes; 256 colors (8-bpp), Thousands of colors (16-bpp), and Millions of colors (32-bpp), and is also measured in bits per pixel (bpp). You can switch your color depth using the ATI Popup Menu, Apple's Control Strip, or the Monitors control panel. Higher bit-depths require more display buffer memory. Note: The ATI 3D Accelerator only functions in Thousands and Millions of colors modes.
Fog	The blending of an object with a fixed color as objects or pixels increase distance away from the viewer.
Frame Buffer	Memory buffer used to store the image being displayed.
Gouraud Shading	One of the more sophisticated shading methods used to produce a smooth lighting effect across a 3D object. A specific color is used at each vertice of a triangle or polygon, and interpolated across the entire face.
MIP Map	Multum In Parvum (Latin) means "many in one." It is a method of increasing quality of a texture map by storing multiple resolutions of the same image and dynamically switching between them depending on the size and depth of the object being textured.
Offscreen Memory	An area of memory used to preload and place images so that they can be quickly drawn on the screen. Offscreen memory refers to all the memory on your ATI accelerator card that is not taken up by the front buffer, which holds the display screen that you see.
Pixel, Pel	Picture element. Smallest addressable area of the computer screen. Pixels on computer displays are square; pixels on NTSC televisions have a 4:3 aspect ratio.
Refresh Rate	Also referred to as "vertical refresh rate". The rate at which a monitor or television can redraw the screen from top to bottom. NTSC television systems have a refresh rate of approximately 60 Hz (but only draw one-half of the video frame in one pass); computer displays typically have refresh rates of 75 Hz or more. At a refresh rate of 70 Hz and lower, screen flicker is often noticeable.
Specular Highlight	The bright, usually small, intense light reflected from a 3-D surface with a high refraction value.

Texture Mapping

Mapping, or placing, an image onto an object. Images of realistic surfaces are placed on 3D models to create a richer and more complex visual effect.

Trilinear Filtering

Sampling method used to produce the most realistic looking 3D objects. Trilinear filtering averages one of the bilinear filter MIP Map levels along with the standard MIP Map samples.

z-buffer

A z-buffer is an area of off-screen memory used to hold “depth” information. For each dot, or pixel, in the display buffer, there is a corresponding dot in the z-buffer which holds the depth (z) value for the display pixel. The depth data helps the ATI accelerator card decide what 3D objects are in front of other 3D objects.

The larger the 3D window, the larger the z-buffer is in memory.



Numerics

3D Graphics

- memory usage 19
- supported features 14

3D Memory Monitor

- description 19

A

Apple Displays

- using DVI adapter 41
- using VGA adapter 2, 42

ATI Displays control panel

- description 11, 15

ATI Guide

- accessing 2, 15, 21
- description 11, 21

D

Display Adapters

- description 8
- obtaining 9

Display Data Channel

- description 8

DVI-to-VGA adapter 41

G

Graphic Card

- features 13
- installation 3, 4, 6, 8
- monitor sensing 8
- requirements 2, 41
- specifications 41
- sync on green 8

I

Installation

- RADEON card 3, 4, 6, 8
- software 11
- warning 3

M

Monitor Resolution

- 2D video mode table 37
- 3D video mode table 39
- changing, Apple displays 17
- changing, VGA displays 17, 18

Q

QuickDraw 3D

- requirements 2
- supported features 14

QuickTime

- accelerated playback 22
- checking video format 23
- optimizing movies 22
- requirements 2, 41
- video formats accelerated 23

S

Software

- 3D Memory Monitor 19
- ATI Displays 11, 15
- ATI Guide 11, 21
- installation 11
- older ATI extensions 4
- requirements 2, 41

T

Troubleshooting

- computer stops responding 4
- contacting customer support 21
- generating problem report 21
- incorrect resolution 18

V

Video Card

- features 13
- installation 3, 4, 6, 8
- monitor sensing 8
- requirements 2, 41
- specifications 41
- sync on green 8